

**Verschluss UNI-JET  
Falzluft 4 mm  
Dreh-Kipp-Beschlag  
Kipp-Dreh-Beschlag**

Getriebebesitz konstant	FFB	400 - 750	400 - 750	751 - 1600	751 - 1600	501 - 1200
	FFH	450 - 720	721 - 1850	450 - 720	751 - 1850	1851 - 2350
Getriebebesitz variabel	FFB	400 - 750	400 - 750	751 - 1600	751 - 1600	501 - 1200
	FFH	480 - 750	751 - 1950	480 - 750	751 - 1950	1951 - 2450

Pos	Benennung	mit 2 Pilzzapfen mit 1 Pilzzapfen	Artikel-Nr.																																												
1	Eckmolenkung		6-31753 6-32021																																												
2	Scherenstulp	<table border="1"> <tr><th>FFB</th><th>Länge</th><th>MV</th></tr> <tr><td>280-400</td><td>350</td><td>-</td></tr> <tr><td>401-500</td><td>350</td><td>-</td></tr> <tr><td>501-750</td><td>590</td><td>-</td></tr> <tr><td>751-1000</td><td>840</td><td>1</td></tr> <tr><td>951-1200</td><td>1040</td><td>1</td></tr> <tr><td>1201-1450</td><td>1290</td><td>1</td></tr> </table>	FFB	Länge	MV	280-400	350	-	401-500	350	-	501-750	590	-	751-1000	840	1	951-1200	1040	1	1201-1450	1290	1	6-31512-03 6-31512-03 6-31512-06 6-31512-08 6-31512-10 6-31512-12																							
FFB	Länge	MV																																													
280-400	350	-																																													
401-500	350	-																																													
501-750	590	-																																													
751-1000	840	1																																													
951-1200	1040	1																																													
1201-1450	1290	1																																													
	Zusatzschere (Dreh-Kipp)	[2]	8-00734																																												
	Zusatzschere (Kipp-Dreh)	[2]	G-45995																																												
3	Drehgriff Dirigent F	1 Stück	6-28072-29																																												
4	Senkschraube DIN 965 M5x35	2 Stück	9-13255-35-R																																												
5	Getriebe 15 GK konstant	<table border="1"> <tr><th>FFH</th><th>Länge</th><th>MV</th><th>Getriebebesitz G</th></tr> <tr><td>360-490</td><td>363</td><td>-</td><td>155</td></tr> <tr><td>450-550</td><td>390</td><td>-</td><td>155</td></tr> <tr><td>551-720</td><td>560</td><td>-</td><td>200</td></tr> <tr><td>721-850</td><td>690</td><td>1</td><td>250</td></tr> <tr><td>851-1100</td><td>940</td><td>1</td><td>400</td></tr> <tr><td>1101-1350</td><td>1190</td><td>1</td><td>500</td></tr> <tr><td>1351-1600</td><td>1440</td><td>2</td><td>600</td></tr> <tr><td>1601-1850</td><td>1690</td><td>3</td><td>600</td></tr> <tr><td>1851-2100</td><td>1940</td><td>3</td><td>980</td></tr> <tr><td>2101-2350</td><td>2190</td><td>4</td><td>980</td></tr> </table>	FFH	Länge	MV	Getriebebesitz G	360-490	363	-	155	450-550	390	-	155	551-720	560	-	200	721-850	690	1	250	851-1100	940	1	400	1101-1350	1190	1	500	1351-1600	1440	2	600	1601-1850	1690	3	600	1851-2100	1940	3	980	2101-2350	2190	4	980	G-22120 G-22121 G-22122 G-22123 G-22124 G-22125 G-22127 G-22128 G-22133 G-22134
FFH	Länge	MV	Getriebebesitz G																																												
360-490	363	-	155																																												
450-550	390	-	155																																												
551-720	560	-	200																																												
721-850	690	1	250																																												
851-1100	940	1	400																																												
1101-1350	1190	1	500																																												
1351-1600	1440	2	600																																												
1601-1850	1690	3	600																																												
1851-2100	1940	3	980																																												
2101-2350	2190	4	980																																												
6	Getriebe 15 GV variabel	<table border="1"> <tr><th>FFH</th><th>Länge</th><th>MV</th><th>Getriebebesitz G</th></tr> <tr><td>480-590</td><td>270</td><td>-</td><td>240-295</td></tr> <tr><td>591-750</td><td>430</td><td>-</td><td>295-375</td></tr> <tr><td>751-1200</td><td>880</td><td>1</td><td>375-600</td></tr> <tr><td>951-1450</td><td>1130</td><td>1</td><td>475-725</td></tr> <tr><td>1201-1700</td><td>1380</td><td>2</td><td>600-850</td></tr> <tr><td>1451-1950</td><td>1630</td><td>2</td><td>725-975</td></tr> <tr><td>1951-2450</td><td>2130</td><td>3</td><td>975-1225</td></tr> </table>	FFH	Länge	MV	Getriebebesitz G	480-590	270	-	240-295	591-750	430	-	295-375	751-1200	880	1	375-600	951-1450	1130	1	475-725	1201-1700	1380	2	600-850	1451-1950	1630	2	725-975	1951-2450	2130	3	975-1225	G-22080 G-22081 G-22082 G-22083 G-22084 G-22085 G-22086												
FFH	Länge	MV	Getriebebesitz G																																												
480-590	270	-	240-295																																												
591-750	430	-	295-375																																												
751-1200	880	1	375-600																																												
951-1450	1130	1	475-725																																												
1201-1700	1380	2	600-850																																												
1451-1950	1630	2	725-975																																												
1951-2450	2130	3	975-1225																																												
7	Ansatzstück 180° für Getriebe GV		6-32303																																												
8	Verriegelung DK	<table border="1"> <tr><th>FFB</th><th>Länge</th><th>MV</th></tr> <tr><td>280-750</td><td>215</td><td>1</td></tr> <tr><td>751-950</td><td>530</td><td>2</td></tr> <tr><td>951-1200</td><td>740</td><td>2</td></tr> <tr><td>1201-1600</td><td>1050</td><td>3</td></tr> </table>	FFB	Länge	MV	280-750	215	1	751-950	530	2	951-1200	740	2	1201-1600	1050	3	6-32012 6-32076-05 6-32076-07 6-32076-10																													
FFB	Länge	MV																																													
280-750	215	1																																													
751-950	530	2																																													
951-1200	740	2																																													
1201-1600	1050	3																																													
9	Verriegelung DK																																														
10	Auflauf		9-41796																																												
11	Verriegelung Bandseite Getriebebesitz konstant	<table border="1"> <tr><th>FFH</th><th>Länge</th><th>MV</th></tr> <tr><td>721-1100</td><td>530</td><td>1</td></tr> <tr><td>1101-1350</td><td>740</td><td>1</td></tr> <tr><td>1351-1850</td><td>1190</td><td>2</td></tr> <tr><td>1851-2100</td><td>1450</td><td>2</td></tr> <tr><td>2101-2350</td><td>1890</td><td>3</td></tr> </table>	FFH	Länge	MV	721-1100	530	1	1101-1350	740	1	1351-1850	1190	2	1851-2100	1450	2	2101-2350	1890	3	6-32075-05 6-32075-07 6-32075-12 6-32075-15 6-32075-19																										
FFH	Länge	MV																																													
721-1100	530	1																																													
1101-1350	740	1																																													
1351-1850	1190	2																																													
1851-2100	1450	2																																													
2101-2350	1890	3																																													
	Verriegelung Bandseite Se Getriebebesitz konstant	<table border="1"> <tr><th>FFH</th><th>Länge</th><th>MV</th></tr> <tr><td>721-1100</td><td>530</td><td>2</td></tr> <tr><td>1101-1350</td><td>740</td><td>2</td></tr> <tr><td>1351-1850</td><td>1190</td><td>3</td></tr> <tr><td>1851-2100</td><td>1450</td><td>3</td></tr> <tr><td>2101-2350</td><td>1890</td><td>4</td></tr> </table>	FFH	Länge	MV	721-1100	530	2	1101-1350	740	2	1351-1850	1190	3	1851-2100	1450	3	2101-2350	1890	4	6-32008-05 6-32008-07 6-32008-12 6-32008-15 6-32008-19																										
FFH	Länge	MV																																													
721-1100	530	2																																													
1101-1350	740	2																																													
1351-1850	1190	3																																													
1851-2100	1450	3																																													
2101-2350	1890	4																																													
	Verriegelung Bandseite Getriebebesitz variabel	<table border="1"> <tr><th>FFH</th><th>Länge</th><th>MV</th></tr> <tr><td>721-1100</td><td>530</td><td>1</td></tr> <tr><td>1101-1350</td><td>740</td><td>1</td></tr> <tr><td>1351-1700</td><td>1190</td><td>2</td></tr> <tr><td>1701-2100</td><td>1450</td><td>2</td></tr> <tr><td>2101-2450</td><td>1890</td><td>3</td></tr> </table>	FFH	Länge	MV	721-1100	530	1	1101-1350	740	1	1351-1700	1190	2	1701-2100	1450	2	2101-2450	1890	3	6-32075-05 6-32075-07 6-32075-12 6-32075-15 6-32075-19																										
FFH	Länge	MV																																													
721-1100	530	1																																													
1101-1350	740	1																																													
1351-1700	1190	2																																													
1701-2100	1450	2																																													
2101-2450	1890	3																																													
	Verriegelung Bandseite Se Getriebebesitz variabel	<table border="1"> <tr><th>FFH</th><th>Länge</th><th>MV</th></tr> <tr><td>721-1100</td><td>530</td><td>2</td></tr> <tr><td>1101-1350</td><td>740</td><td>2</td></tr> <tr><td>1351-1700</td><td>1190</td><td>3</td></tr> <tr><td>1701-2100</td><td>1450</td><td>3</td></tr> <tr><td>2101-2450</td><td>1890</td><td>4</td></tr> </table>	FFH	Länge	MV	721-1100	530	2	1101-1350	740	2	1351-1700	1190	3	1701-2100	1450	3	2101-2450	1890	4	6-32008-05 6-32008-07 6-32008-12 6-32008-15 6-32008-19																										
FFH	Länge	MV																																													
721-1100	530	2																																													
1101-1350	740	2																																													
1351-1700	1190	3																																													
1701-2100	1450	3																																													
2101-2450	1890	4																																													
12	Pilzkopfkippschließplatte NL9 NL13	1 Stück	6-32305 6-34629																																												
13	Schließplatte		8-00872																																												
14	Unterlage Schließplatte für NL13	Anzahl der Schließplatten nach verwendeter Elementgröße	9-44753-01-R/L																																												
15	Schließplatte Eurofalz 18x8 NL9		9-42301-18																																												
	Schließplatte Eurofalz 24x8 NL13		9-42654-00																																												
16	Schließplatte KD	1 Stück	6-32668																																												

(1) FFB 280-400, FFH 350-450 nur mit Eckmolenkung S 6-32238 und Öffnungsbegrenzer 8-00775  
 (2) FFB 1451-1600 Zusatzschere verwenden oder Verlängerung 500 gekürzt auf 250mm mit MV

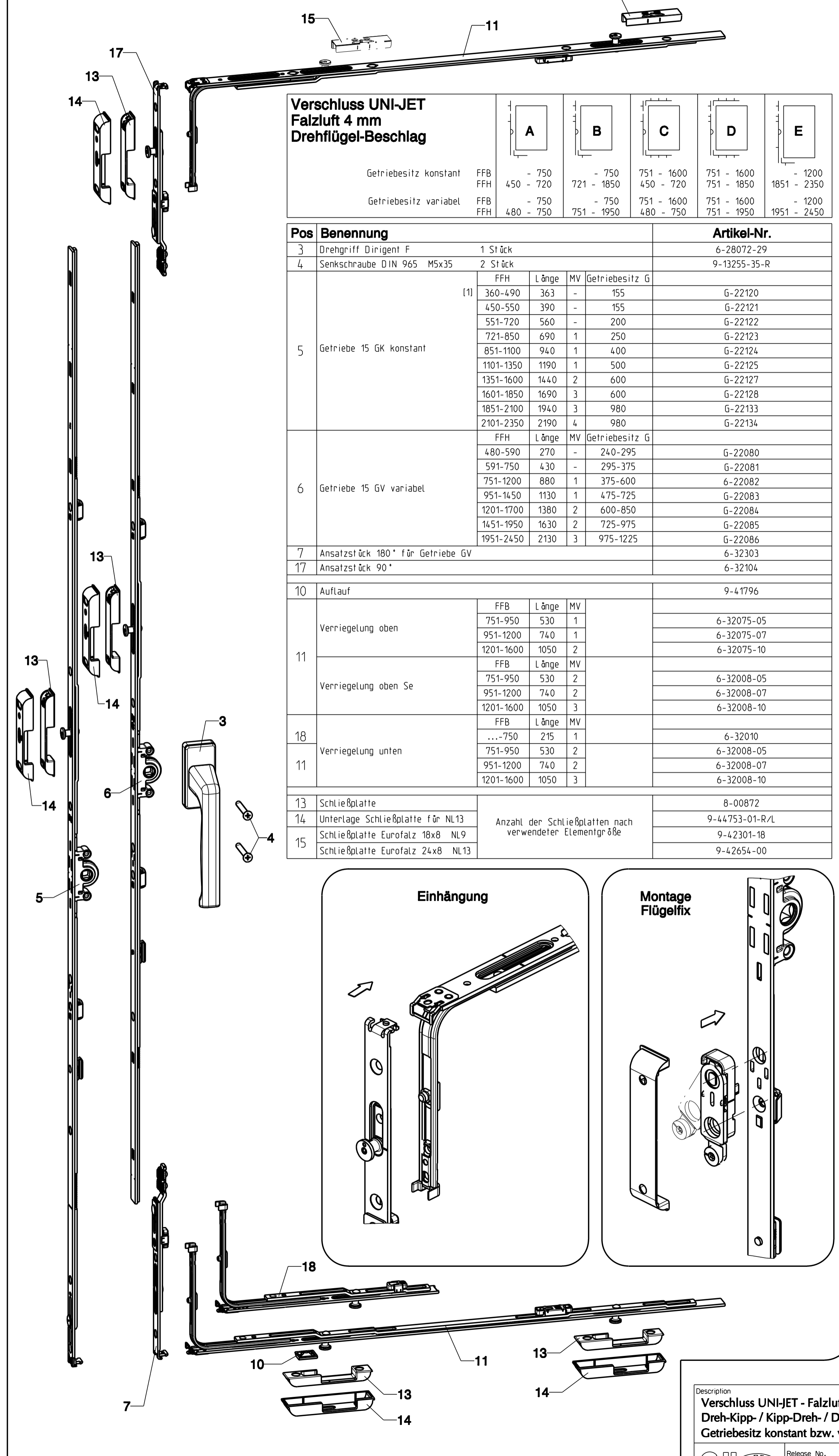
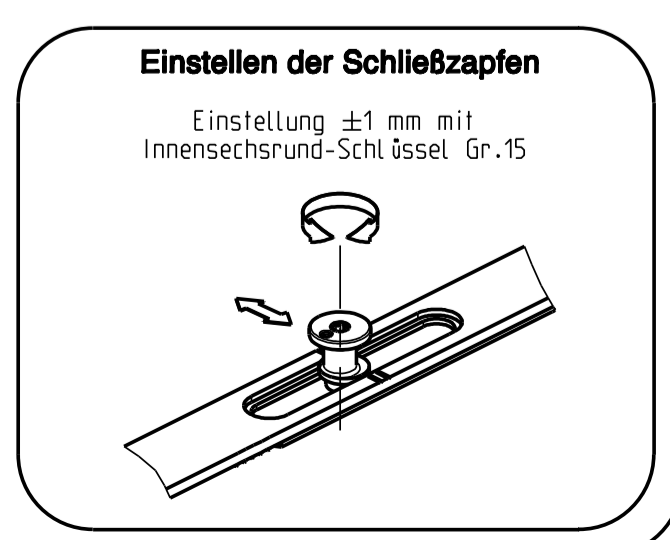

**Verschluss UNI-JET  
Falzluft 4 mm  
Drehflügel-Beschlag**

Pos	Benennung	1 Stück	Artikel-Nr.																																												
3	Drehgriff Dirigent F	1 Stück	6-28072-29																																												
4	Senkschraube DIN 965 M5x35	2 Stück	9-13255-35-R																																												
5	Getriebe 15 GK konstant	<table border="1"> <tr><th>FFH</th><th>Länge</th><th>MV</th><th>Getriebebesitz G</th></tr> <tr><td>360-490</td><td>363</td><td>-</td><td>155</td></tr> <tr><td>450-550</td><td>390</td><td>-</td><td>155</td></tr> <tr><td>551-720</td><td>560</td><td>-</td><td>200</td></tr> <tr><td>721-850</td><td>690</td><td>1</td><td>250</td></tr> <tr><td>851-1100</td><td>940</td><td>1</td><td>400</td></tr> <tr><td>1101-1350</td><td>1190</td><td>1</td><td>500</td></tr> <tr><td>1351-1600</td><td>1440</td><td>2</td><td>600</td></tr> <tr><td>1601-1850</td><td>1690</td><td>3</td><td>600</td></tr> <tr><td>1851-2100</td><td>1940</td><td>3</td><td>980</td></tr> <tr><td>2101-2350</td><td>2190</td><td>4</td><td>980</td></tr> </table>	FFH	Länge	MV	Getriebebesitz G	360-490	363	-	155	450-550	390	-	155	551-720	560	-	200	721-850	690	1	250	851-1100	940	1	400	1101-1350	1190	1	500	1351-1600	1440	2	600	1601-1850	1690	3	600	1851-2100	1940	3	980	2101-2350	2190	4	980	G-22120 G-22121 G-22122 G-22123 G-22124 G-22125 G-22127 G-22128 G-22133 G-22134
FFH	Länge	MV	Getriebebesitz G																																												
360-490	363	-	155																																												
450-550	390	-	155																																												
551-720	560	-	200																																												
721-850	690	1	250																																												
851-1100	940	1	400																																												
1101-1350	1190	1	500																																												
1351-1600	1440	2	600																																												
1601-1850	1690	3	600																																												
1851-2100	1940	3	980																																												
2101-2350	2190	4	980																																												
6	Getriebe 15 GV variabel	<table border="1"> <tr><th>FFH</th><th>Länge</th><th>MV</th><th>Getriebebesitz G</th></tr> <tr><td>480-590</td><td>270</td><td>-</td><td>240-295</td></tr> <tr><td>591-750</td><td>430</td><td>-</td><td>295-375</td></tr> <tr><td>751-1200</td><td>880</td><td>1</td><td>375-600</td></tr> <tr><td>951-1450</td><td>1130</td><td>1</td><td>475-725</td></tr> <tr><td>1201-1700</td><td>1380</td><td>2</td><td>600-850</td></tr> <tr><td>1451-1950</td><td>1630</td><td>2</td><td>725-975</td></tr> <tr><td>1951-2450</td><td>2130</td><td>3</td><td>975-1225</td></tr> </table>	FFH	Länge	MV	Getriebebesitz G	480-590	270	-	240-295	591-750	430	-	295-375	751-1200	880	1	375-600	951-1450	1130	1	475-725	1201-1700	1380	2	600-850	1451-1950	1630	2	725-975	1951-2450	2130	3	975-1225	G-22080 G-22081 G-22082 G-22083 G-22084 G-22085 G-22086												
FFH	Länge	MV	Getriebebesitz G																																												
480-590	270	-	240-295																																												
591-750	430	-	295-375																																												
751-1200	880	1	375-600																																												
951-1450	1130	1	475-725																																												
1201-1700	1380	2	600-850																																												
1451-1950	1630	2	725-975																																												
1951-2450	2130	3	975-1225																																												
7	Ansatzstück 180° für Getriebe GV		6-32303																																												
17	Ansatzstück 90°		6-32104																																												
10	Auflauf		9-41796																																												
11	Verriegelung oben	<table border="1"> <tr><th>FFB</th><th>Länge</th><th>MV</th></tr> <tr><td>751-950</td><td>530</td><td>1</td></tr> <tr><td>951-1200</td><td>740</td><td>1</td></tr> <tr><td>1201-1600</td><td>1050</td><td>2</td></tr> </table>	FFB	Länge	MV	751-950	530	1	951-1200	740	1	1201-1600	1050	2	6-32075-05 6-32075-07 6-32075-10																																
FFB	Länge	MV																																													
751-950	530	1																																													
951-1200	740	1																																													
1201-1600	1050	2																																													
	Verriegelung oben Se	<table border="1"> <tr><th>FFB</th><th>Länge</th><th>MV</th></tr> <tr><td>751-950</td><td>530</td><td>2</td></tr> <tr><td>951-1200</td><td>740</td><td>2</td></tr> <tr><td>1201-1600</td><td>1050</td><td>3</td></tr> </table>	FFB	Länge	MV	751-950	530	2	951-1200	740	2	1201-1600	1050	3	6-32008-05 6-32008-07 6-32008-10																																
FFB	Länge	MV																																													
751-950	530	2																																													
951-1200	740	2																																													
1201-1600	1050	3																																													
18	Verriegelung unten	<table border="1"> <tr><th>FFB</th><th>Länge</th><th>MV</th></tr> <tr><td>...-750</td><td>215</td><td>1</td></tr> <tr><td>751-950</td><td>530</td><td>2</td></tr> <tr><td>951-1200</td><td>740</td><td>2</td></tr> <tr><td>1201-1600</td><td>1050</td><td>3</td></tr> </table>	FFB	Länge	MV	...-750	215	1	751-950	530	2	951-1200	740	2	1201-1600	1050	3	6-32010 6-32008-05 6-32008-07 6-32008-10																													
FFB	Länge	MV																																													
...-750	215	1																																													
751-950	530	2																																													
951-1200	740	2																																													
1201-1600	1050	3																																													
13	Schließplatte		8-00872																																												
14	Unterlage Schließplatte für NL13	Anzahl der Schließplatten nach verwendeter Elementgröße	9-44753-01-R/L																																												
15	Schließplatte Eurofalz 18x8 NL9		9-42301-18																																												
	Schließplatte Eurofalz 24x8 NL13		9-42654-00																																												

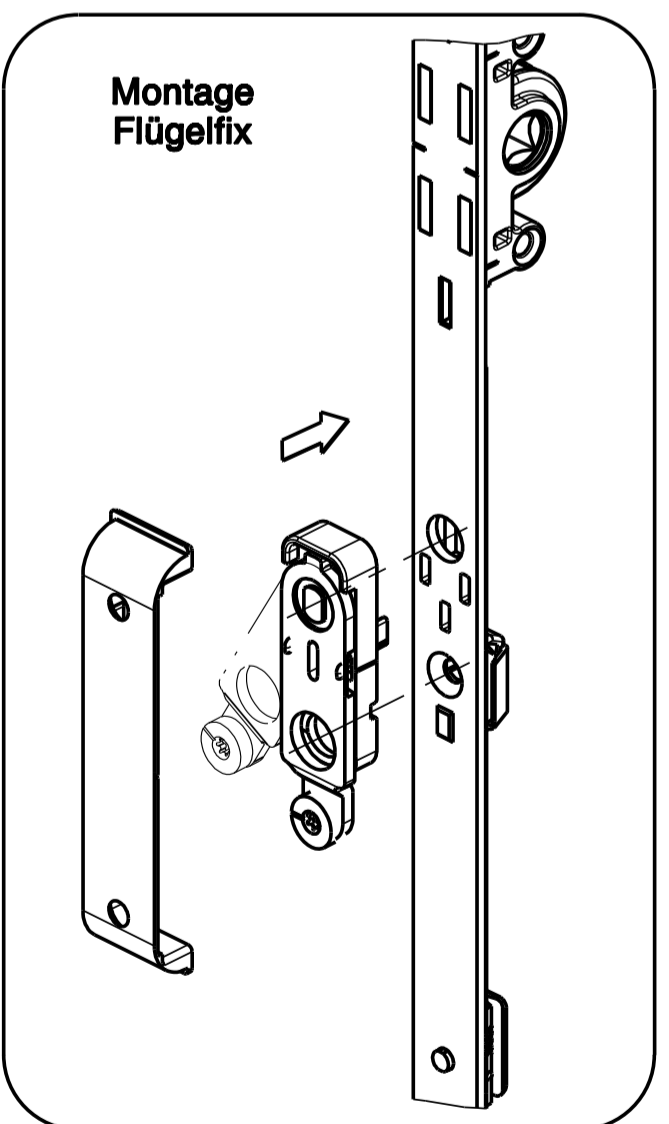
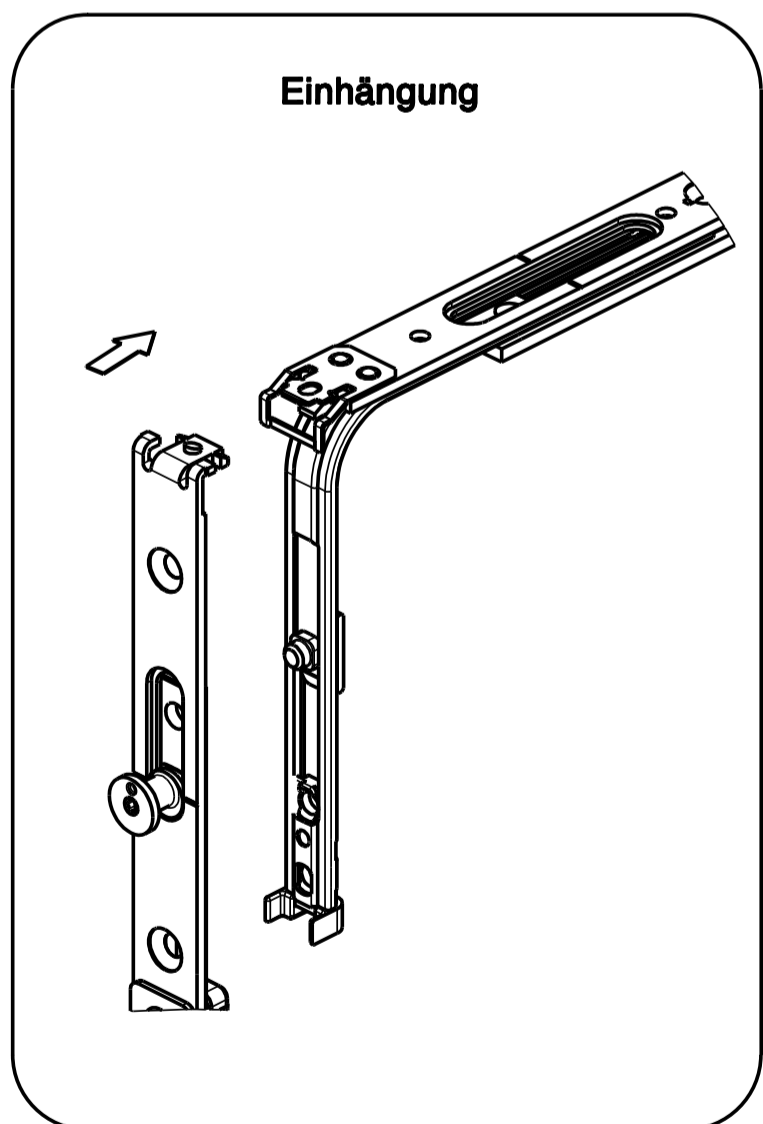

Wunschteile			
Pos	Benennung	Artikel-Nr.	
19	Eckmolenkung S	6-32238	
20	Eckmolenkung SLK	6-32224	
21	Verlängerung 250	8-00625	
22	Verlängerung 500	6-32142	
23	Halterungsplatte für Drehflügel	9-35697	
24	Türschnapper	K-15437	
25	Unterlage Türschnapper für NL13	9-44753-04	
26	Flügelfix mit Fehlbedienungsicherung	6-29987	
27	Auflaufplatte	9-40244	
28	Unterlage Auflaufplatte für NL13	9-44760	
29	Drehgriff Dirigent abziehbar	8-00694-33	
30	Rosette	6-24913	
31	Füllstulp	H-00786	
32	Mittelband	Flügelteil Rahmen teil	9-40564 9-41504
33	Öffnungsbegrenzer DK	FFB	8-00775
		500-750	9-42768-33-R/L
		751-...	9-41750-63

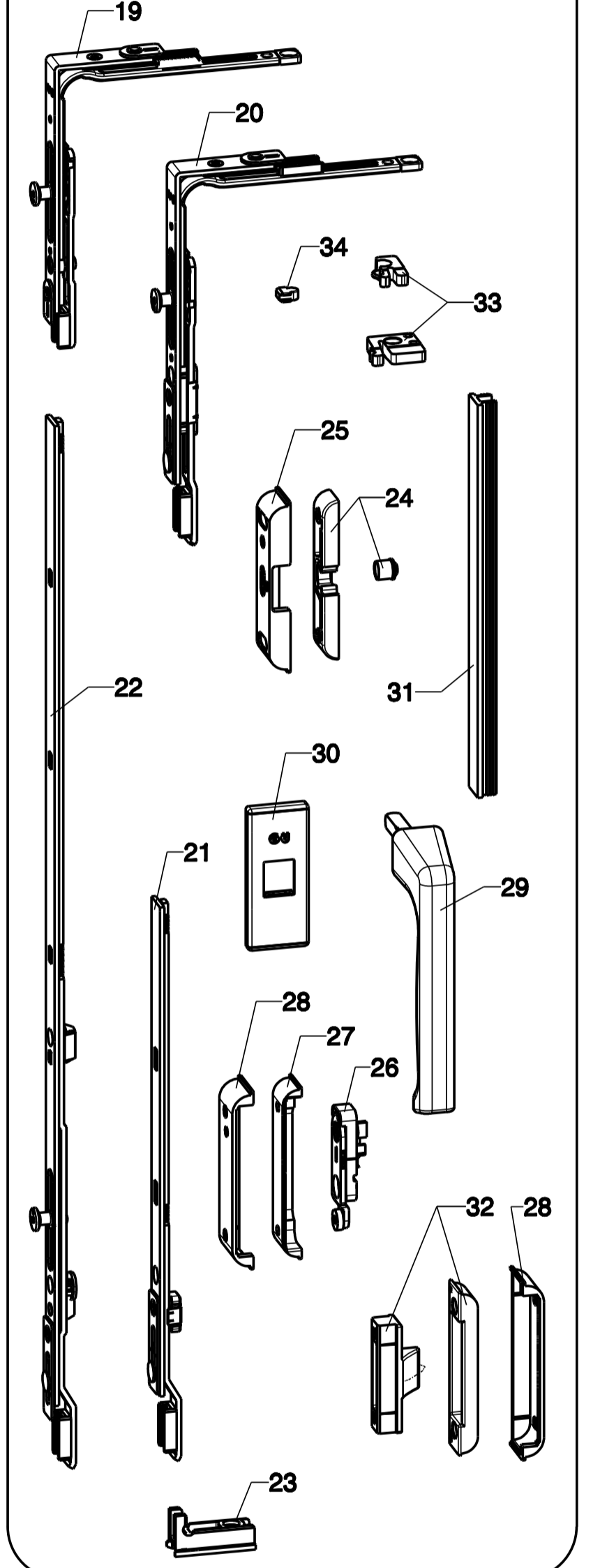

max. Flügelalzbreite FFB 1600 mm  
 max. Flügelalzhöhe FFH 2350 mm (konstant)  
 max. Flügelalzhöhe FFH 2450 mm (variabel)

unbedingt Produktinformation beachten  
 (siehe G.U.-Bestellkatalog)

Erforderliche Bestellangaben:  
 Flügelalzbreite FFB  
 Flügelalzhöhe FFH  
 Getriebebesitz konstant oder variabel  
 Beschlagnutlage 9 mm bzw. 13 mm  
 Wunschteile

Bei Flügelalzbreiten über 1200 mm  
 oder Flügelgewichten über 100 kg  
 Zusatzschere erforderlich.  
 Einbau nach W.Z. 0-43291-DD-3 (Dreh-Kipp)  
 bzw. W.Z. 0-43743-DD-3 (Kipp-Dreh)

Einbau Bandseite siehe Zeichnung-Nr.  
 0-44353-DC-2 UNI-JET M 6/4

Description		Scale		Modification		Size
Verschluss UNI-JET - Falzluft 4 mm Dreh-Kipp- / Kipp-Dreh- / Drehflügel-Beschlag Getriebebesitz konstant bzw. variabel, Beschlagnutlage 9 mm bzw. 13 mm		5		5		1
Release No. 7741	Level released	Ver. --	Sp 5p	% 5	Modifikation To	Sheet 1
Mod. No. --	Scale 1:1	Draft 01.07.04	Scale 5	Scale 5	Scale 5	Scale 5
Replacement for --						0-44354-DC

